

Symbol Detection in Complex Technical Drawings

Task

Technical drawings are a universal medium for conveying detailed information across industries such as engineering, architecture, and manufacturing. These drawings rely on standardized symbols to represent components, connections, and processes. Symbols serve as the foundation for interpreting and implementing designs, making their accurate identification critical for automating workflows and ensuring consistency.

This project focuses on **symbol detection in complex technical drawings**, aiming to automate the recognition and classification of symbols using **Artificial Intelligence (AI)**. The task involves the **creation of a dataset** of diverse technical drawings, followed by testing and evaluating various AI models to identify the best-performing solution for accurate symbol detection.

- **Dataset Creation:** Gather and label diverse technical drawings with symbol annotations.
- **Data Preprocessing:** Clean, enhance, and augment drawings for better model training.
- **Model Training:** Train object detection models (e.g., YOLO, Faster R-CNN) on the dataset.
- **Model Evaluation:** Measure performance with precision, recall, and mAP metrics.
- **Validation:** Test the system on new drawings and refine based on results.

Project Characteristics

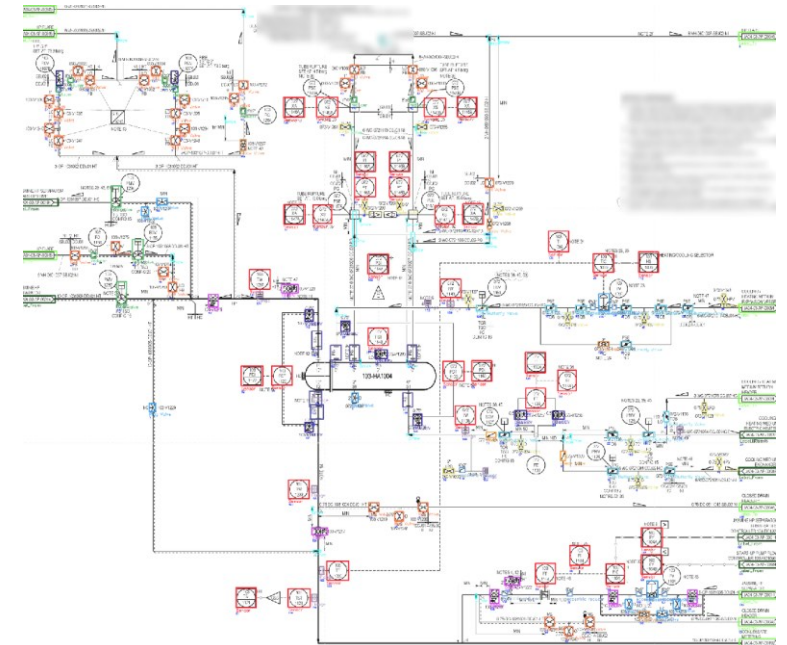
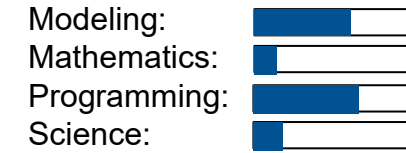

Source: [1]

[1] Elyan, E., Jamieson, L., & Ali-Gombe, A. (2020). Deep learning for symbols detection and classification in engineering drawings. *Neural networks*, 129, 91-102.